

MANUAL



Blaze-Grating-Spektroskop/Spektrograph

of N.Sommer

Introduction

The light of all astronomical objects contains three kinds of important, totally different Information. First the *direction* can be determined, from where it comes, enabling us to measure the Position and distance of the source. Secondly, its *intensity* can be investigated, so the luminosity and its eventual variations are evaluable. Thirdly, looking at the *spectrum* one can analyse the chemical composition, radial velocity, surface temperature and the type and structure of the source of light. Furthermore the spectrum allows us to ascertain the otherwise determined source's distance using a different method. Spectrographs split up the component wavelengths (colors) of light and use either prisms, gratings or combinations of these. Prisms form only one spectrum but with very uneven dispersing power, so spectral lines are more crowded at red wavelengths than at blue. A further disadvantage is the faintness of the spectrum for the important blue region of wavelengths because of the strong absorption in the glass-substrate and the especially high dispersion of blue light. So determination of specific wavelengths is more complex. On the other side, beneath an unchanged part of light (zero order) gratings deliver several higher order spectra (1st & higher orders), which show nearly constant dispersion for all colors from red to blue light and high intensity for the shorter wavelengths. The Shortcoming of producing several spectra is greatly lessened by the Special figuring of the grooves, thus directing most of the light into one of two 1st order spectra. This effectively results in much brighter spectra, just like using a telescope of considerably greater aperture. The special figuring of the grooves is called "blazing" and is incorporated in the process of laser holographic manufacturing. Beginning with the 2nd order, its red end overlaps with the violet end of the next higher order spectrum /10/. Therefore the grating of this spectrograph is blazed for the 1st order to ensure maximum intensity and prevent any superposition of spectra. At low magnification there can be seen zero and first order spectra simultaneously, greatly facilitating the identification of the object and corresponding spectrum. Simply switching to greater magnification ensures exact investigation.

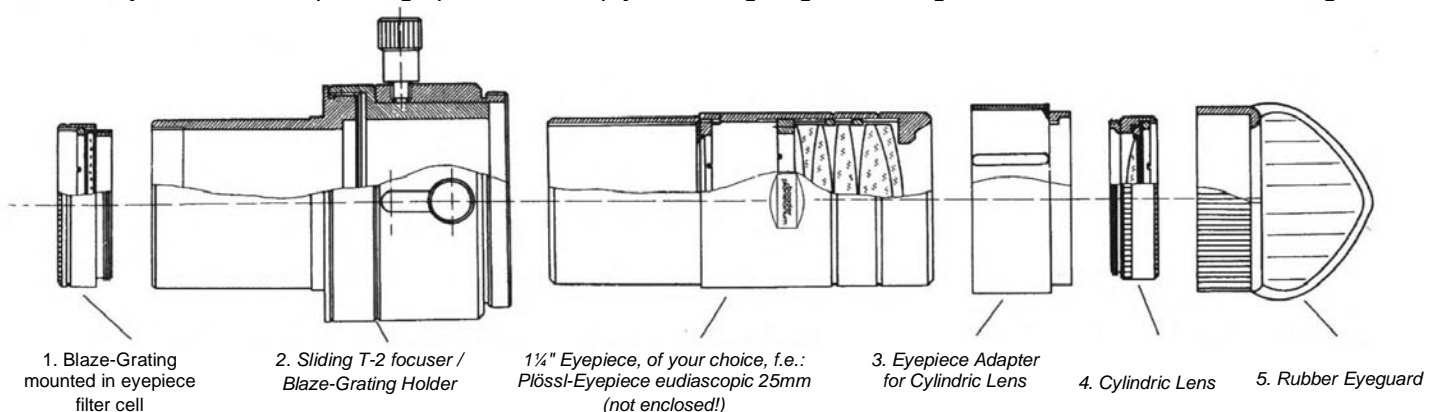

Using the Spectroscope / Spectrograph

First remember the grooves of a grating are very delicate and have to be protected from fingerprints and scratches. Cleaning them is impossible, but dust can be blown off with compressed air. For protection the grating should be put in the box when not using it.

The spectroscope is easy to use in either mode. First, carefully attach the grating to the grating holder. Next, insert a low power eyepiece into the other end of the grating holder. Tighten the thumbscrew to lock the eyepiece in. Note that the second thumbscrew is for photography and fastens the outer extension tube at the desired length. Insert the spectroscope assembly into the telescope's focuser and aim at a bright star. Focus as usual and align the telescope so that the zero order point like image and the brightest (first) order linear spectrum are centered in the field of view. Now add the cylindrical lens (and eyeshade if desired). Set the cylindrical lens so that the zero order image appears as a line perpendicular to the 1st order spectrum, which now appears as a band of colors. Refocus slightly so the edges of the spectrum are sharp; this will make the zero order image bulge in the middle.

Addition for Newtonian telescopes

Normally this type of telescope has a smaller range of focussing travel than others. So eventually any extending bushing of the drawtube has to be removed. In case this should be impossible, the grating is screwed directly to the eyepiece.

Most optical Systems with secondary mirrors (Newtonian/Schmidt-Cassegrain) will show their central shading as a slightly darker region in the middle of the colored band. The use of the cylindrical lens depends on the type of object. Emission line objects are Planetary Nebulae (PN; e.g. NGC 7662 in And), small and bright Gaseous Nebulae (GN; e.g. NGC 1999 in Ori) and some Wolf-Rayet-Stars (WRS; e.g. β 1207 in Cyg) which show their spectral details (monochromatic images of PN's and GN's, the continuous spectra of WRS and central stars of PN or the emission bands of the WRS) without the cylindrical lens. All other types of objects require the use of this lens for widening the spectrum in order to see the absorption lines or bands. Some observers prefer tapping the telescope slightly so that the widening of the spectrum is accomplished by such vibrations. It must be emphasized, that the visibility of spectral lines depends to the same extent on good seeing and image contrast (that is the contrast between absorption/emission lines and adjacent parts of the spectrum) as in observing (without spectroscope) double stars and details on planetary surfaces. Finally, proper collimation of the telescope and growing experience of the observer enables one to discern more and more subtle details. By screwing the grating into a separate adapter instead of to the eyepiece, changing the magnification is merely a matter of seconds without disturbing the orientation of objects in the field of view. So after examining spectral details of one object, picking up the next at lower magnification and greater field of view is an easy task. As mentioned before, the unchanged part of light, transmitting the grating, is called zero order. In some PN's this part of light may be very faint or even invisible and there can be confusion with its [OIII] image. Turning the grating or the spectral assembly respectively will immediately discern the non-rotating zero order from the rotating spectral image. Producing the spectral line over their blue end always leads to the zero order image. With a fast telescope, insertion of a grating into the convergent beam of light causes aberrations. With constant distance of the grating from the focal plane, as in the assumed case, the introduced coma is inversely proportional to the number of grooves per inch, astigmatism varies as the square of the reciprocal of the grooves spacing. For a given grating, aberrations are minimized for a maximum distance from the focal plane $/13/$.

Even if mounted perpendicularly to the optical axis of the drawtube just like the one used here, every grating will deviate incoming light. Especially at low magnifications this results in the vignetting of the field of view visible on one edge, because in a blazed grating both sequences of orders are not of equal intensity. The vignetting follows the turning of the grating.

Often there is a rule to be considered: the smaller the angular diameter of an observed PN, the higher its surface brightness. This has several consequences for observation. First, resolution of close monochromatic images is better for there is not as much superposition. With high magnification, this effect is very prominent when observing the [OIII]-lines (495.9/500.7 nm) at PN of increasing angular diameter. They seem to be clearly resolved or only elliptically elongated or unresolved, yet in shape of the PN. Higher surface brightness means better contrast of images of fainter emission lines compared to the sky background. Especially $H\beta$ (486.1 nm) and HeI (587.6 nm), whose intensities strongly depend on the excitation class of the PN $/1/$, are in most cases too weak to be observed.

The human eyes, especially the very sensitive rods of their retina, are not able to perceive the strong but very red $H\alpha$ -line at low illumination conditions, e.g. by faint objects in the sky $/4/$. If there are modifications of the PN's shape after insertion of the spectroscope this may result from the spectrum of the otherwise undistinguishable central star.

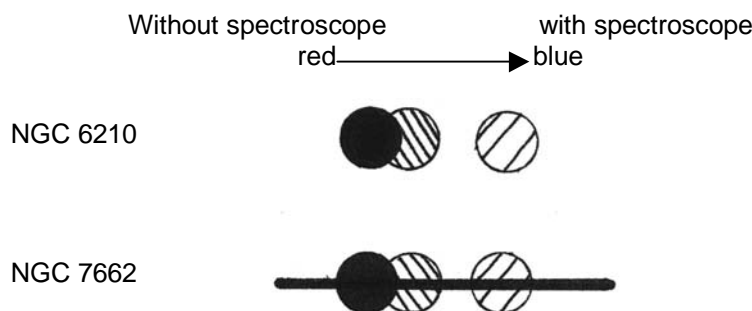

It has to be considered that the Separation of monochromatic images of PN is neither a function of the telescope's magnification nor of its focal length. It solely depends on the distance between the grating and focal plane. On the other hand the apparent diameter of the PN in the focal plane is determined by focal length. So it may happen that a telescope of a smaller focal length works better with this spectroscope at separating the [OIII]-lines of a certain PN because of lesser superposition of their images. A bigger telescope of longer focal length will surpass the former on smaller and fainter objects. The following picture illustrates the Situation.



The radiation of GN and PN is composed of discrete lines / colors and may therefore be split by the grating in only a handful of discrete monochromatic images. So it is not as "diluted" as the light of stars, increasing the limiting magnitude considerably. To a certain extent this also applies to WRS. The chromatic aberration of refractors with normal lenses lets rays of different wavelengths / colors converge on different focal planes, resulting in what is called a *secondary spectrum*. So each spectrum in the telescope's field of view should be focussed separately on a tilted plane, which is technically impossible. This imperfection is not severe. The human eye accommodates for this. Reflectors, Fluorite- and apochromatic refractors are not affected by chromatic aberration.

List of Objects of different spectral type

		α 2000 h m	δ 2000 o	Spektral- type	m_v remarks
β -Cas		00 09.2	+ 59 09	F5	2.3 Caph
NGC 40		00 13.0	+ 72 32	PN	10.7
α -Cas		00 40.6	+ 56 33	K0	2.3 Shedar
IC 1644		01 09.2	- 73 12	PN	- from /6/
β -And	*	01 09.7	+ 35 37	M0	2.1 Mirach
β -Per		03 08.1	+ 40 58	B8	2.1-3.4 Algol
α -Per		03 24.2	+ 49 52	F5	1.8 Mirfak
BD-Cam		03 42.2	+ 63 13	S5	5.0-5.2
IC 351		03 47.5	+ 35 03	PN	12.4
IC 2003		03 56.4	+ 33 52	PN	12.6
ξ -Per		03 59.0	+ 35 47	07	4.0 Menkib
NGC 1535		04 14.2	- 12 44	PN	9.6
α -Tau	*	04 35.8	+ 16 31	K5	0.9 Aldebaran
R Dor	*	04 36.8	- 62 05	M8	4.8-6.6
NGC 1714		04 52.1	- 66 55	GN	-
α -Cam		04 54.1	+ 66 21	09	4.3
R-Lep	*	04 59.6	- 14 48	C6	5.9-10.5
W-Ori		05 05.4	+ 01 11	C6	6.2-7.0
J 320		05 05.6	+ 10 42	PN	12.9
β -Ori		05 14.6	- 08 12	B8	0.1 Rigel
α -Aur	*	05 16.7	+ 46 01	G8	0.1 Capella
IC 418	*	05 27.5	- 12 42	PN	12.0
γ -Ori		05 35.1	+ 09 56	08	3.4 Meissa, double
NGC 1931		05 31.4	+ 34 15	GN	- around star - around cluster
NGC 1999	*	05 36.5	- 06 42	GN	- V380 Ori
α -Ori		05 55.1	+ 07 24	M2	0.5-1.3 Betelgeuse
IC 2149	*	05 56.3	+ 46 07	PN	9.9
β -Aur		05 59.6	+ 44 58	A0	1.9 Menkalinan
TU-Gem		06 10.9	+ 26 01	C5	7.3-10.4
η -Gem var.		06 14.9	+ 22 30	M3	3.2-4.2
IC 2165	*	06 21.7	- 12 59	PN	12.5
BL-Ori		06 25.5	+ 14 43	C6	6.2-7.4
J 900		06 25.9	+ 17 47	PN	12.4
RT-Aur		06 28.6	+ 30 30	F4-G1	5.0-5.8 δ -Ceph
V 613-Mon		06 48.4	+ 05 33	S5	7.7
HD 50896		06 54.2	- 23 56	WN5	6.9 WRS
R-Gem		07 07.4	+ 22 42	S2-S8	6.0-14.0
R-Cmi		07 08.8	+ 10 01	C7	7.3-11.6
NGC 2392	*	07 29.2	+ 20 55	PN	8.6 Eskimo-Nebel
α -Gem		07 34.6	+ 31 54	A0	1.6 Castor
α -CMi		07 39.3	+ 05 14	F5	0.4 Procyon
NGC 2440		07 41.9	- 18 13	PN	9.1
β -Gem		07 45.4	+ 28 02	K0	1.1 Pollux
9-Cnc		08 06.3	+ 22 38	M4	6.0
γ -Vel	*	08 09.5	- 47 20	WC7	1.8
X-Cnc	*	08 55.4	+ 17 14	C4	5.6-7.5
IC 2448		09 07.1	- 69 57	PN	11.5
δ_s -UMa		09 10.4	+ 67 08	F7	4.8

		α 2000	δ 2000	Spektral-	m_v remarks
		h m	o	Type	
RS-Cnc		09 10.6	+ 30 58	M6	5.3-6.8
R-Leo		09 47.6	+ 11 26	M8	4.4-11.3
NGC 3132	*	10 07.7	- 40 26	PN	8.2
α -Leo		10 08.4	+ 11 58	B8	1.4 Regulus
IC 2553		10 09.3	- 62 37	PN	9.0
S Car	*	10 09.4	- 61 33	K7-M4	4.5-9.9
NGC 3242	*	10 24.8	- 18 38	PN	9.0
30-Lmi		10 25.9	+ 33 48	F0	4.7
U-Hya	*	10 37.6	- 13 23	C7	7.0-9.2
η -Car	*	10 45.1	- 59 41	pec	6.2 * and nebula
α -Uma		11 03.8	+ 61 45	K0	1.8 Dubhe
VV 60		11 28.6	- 52 56	PN	
NGC 3918		11 50.3	- 57 11	PN	8.4
γ -Cru	*	12 31.2	- 57 07	M4	1.6
IC 3568		12 32.9	+ 82 33	PN	9.0
Y-CVn	*	12 45.1	+ 45 26	C5	5.5-6.0
ε -UMa		12 54.0	+ 55 58	A0	1.8 Alioth
α -Com		13 10.0	+ 17 32	F5	4.3
R-Hya	*	13 29.7	- 23 17	M7	3.0-11.0
η -Uma		13 47.6	+ 49 19	B3	1.9 Alkaid
α -Boo	*	14 15.7	+ 19 13	K0	-0.1 Arcturus
R-Cen	*	14 16.6	- 59 55	M4-M8	5.3-11.8
γ -Boo		14 32.1	+ 38 19	A7	3.0 Seginus
β -Umi		14 50.6	+ 74 10	K4	2.1 Kochab
δ -Lib	*	15 04.1	- 25 17	M4	3.3
α -CrB	*	15 34.7	+ 26 43	A0	2.2 Gemma / Alphecca
IC 4593	*	16 12.2	+ 12 04	PN	10.2
ε -Oph		16 18.3	- 04 42	G8	3.2
γ -Her		16 21.9	+ 19 09	A9	3.8
NGC 6210	*	16 44.5	+ 23 49	PN	9.7
I 4637	*	17 05.2	- 40 53	PN	13.6
NGC 6302	*	17 13.7	- 37 06	PN	12.8 Bug Nebula
NGC 6309	*	17 14.1	- 12 55	PN	9.7
NGC 6445		17 49.2	- 20 01	PN	9.5
γ -Dra		17 56.5	+ 51 30	K5	2.2 Eltanin
NGC 6543	*	17 58.6	+ 66 38	PN	8.8
NGC 6572	*	18 12.1	+ 06 51	PN	9.6
T-Lyr		18 32.3	+ 37 00	C6	7.8-9.6
α -Lyr	*	18 36.8	+ 38 47	A0	0.0 Vega
M 1-59	*	18 43.3	- 09 05	PN	6.5
Hu 2-1	*	18 49.7	+ 20 51	PN	11.5
V-Aql		19 04.6	- 05 41	C5-C6	7.4-8.0
R-Aql	*	19 06.4	+ 08 14	M5-M9	5.5-12.0
δ -Dra		19 12.6	+ 67 40	G9	3.1 Altair
NGC 6790	*	19 23.2	+ 01 31	PN	10.3
RR-Lyr		19 25.5	+ 42 47	A8-F7	7.1-8.1 δ -Ceph
AQ Sgr	*	19 34.3	- 16 22	\wedge C5	9.1-10.9
γ -Cyg		19 50.6	+ 32 55	S6-S10	3.3-6.1
η -Aql		19 52.2	+ 01 00	F6-G4	5.4-6.1 δ -Ceph
HD 189256		19 57.2	+ 44 16	N8	7.8
VZ-Sge	*	20 00.0	+ 17 31	M4	5.3-5.6
HD 190918		20 05.9	+ 35 48	WN5	6.7 WRS
NGC 6884		20 10.4	+ 46 28	PN	12.6
HD 192163		20 12.1	+ 38 21	WN6	7.5 WRS
ND 192281		20 12.5	+ 40 16	O6	7.6
RS-Cyg		20 13.4	+ 38 44	C8	6.5-9.3
HD 192641	*	20 14.5	+ 36 40	WC7	7.4 WRS
HD 193077		20 17.0	+ 37 25	WN5	8.0 WRS
AC-Dra		20 20.1	+ 68 53	M5	5.6
IC 4997		20 20.2	+ 16 45	PN	12.0
HD 193702/193707	*	20 20.5	+ 42 51	WC6	6.0 WRS

		α 2000		δ 2000		Spektral-	m_v	remarks
		h	m	o		type		
ε -Del		20	33.2	+ 11	18	B6	4.0	
β -Del		20	37.5	+ 14	36	F5	3.5	
ε -Cyg		20	46.2	+ 33	58	K0	2.5	
T-Vul		20	51.5	+ 28	15	F5-G0	5.4-6.1	δ -Ceph
NGC 7009		21	04.2	+ 11	22	PN	8.4	Saturn-Nebel
NGC 7027	*	21	07.1	+ 42	14	GN / PN?	10.4	
α -Equ		21	15.8	+ 05	15	G0	3.9	Kitalpha
IC 5117		21	32.5	+ 44	35	PN	10.5	
μ -Cep	*	21	43.5	+ 58	47	M2	3.6-5.1	
16-Peg		21	53.5	+ 25	56	B3	5.1	
α -Aqr		22	05.8	- 00	19	G2	3.0	Sadalmelik
IC.5217		22	23.9	+ 50	58	PN	10.0	
11-Lac		22	40.5	+ 44	17	K3	4.5	
β -Peg	*	23	03.8	+ 28	05	M2	2.4	Scheat
NGC 7662	*	23	25.9	+ 42	33	PN	9.4	
κ -And		23	40.5	+ 44	20	B8	4.1	
R-Aqr	*	23	43.8	- 15	17	M5-M8	5.8-12.4	
TX-Psc		23	46.4	+ 03	29	C6	5.3-5.8	
ω -Psc		23	59.3	+ 06	52	F4	4.0	

The above list contains selected bright stars of all spectral types, PN and small GN. It is not at all complete; further objects can be chosen from /2,3,6/. Details on spectral characteristics are to be found in /7,9,12/. For a first quick survey please refer to the objects marked *.

List of double stars of great color difference

		α 2000		δ 2000		Spectra	d	PA	$m_1 + m_2$
		h	m	o			"	o	
WZ-Cas var.		00	01.3	+ 60	21	C9+A?	58.1	89	7.4-10.1 + 8.7
ADS 1/Cam		00	02.6	+ 66	06	G0+A2	15.2	70	5.9+7.3
35-Cas		01	21.1	+ 64	40	A0+?	55.5	344	6.3+8.7
1-Ari		01	50.1	+ 22	17	G9+A2	2.8	166	6.2+7.4
$\gamma_{1,2}$ -And	*	02	03.9	+ 42	20	K0+A0	9.4	64	2.3+5.1
O $\Sigma\Sigma$ 26/Cas		02	19.7	+ 60	02	A2+G5	63.3	200	6.9+7.4
32-Eri		03	54.3	- 02	57	G5+A2	6.8	347	4.8+6.1
55-Eri		04	43.6	- 08	48	F5+G8	9.2	317	6.7+6.8
11-Cam		05	06.1	+ 58	58	B3+K0	180.5	8	5.4+6.5
O $\Sigma\Sigma$ 79/Mon		06	54.1	+ 06	41	G5+A0	116.1	89	7.2+7.3
ι -Cnc		08	46.7	+ 28	46	G5+A5	30.5	307	4.2+6.6
ADS 8600/Com		12	35.1	+ 18	23	K0+A3	20.3	271	5.2+6.7
32-Com		12	52.2	+ 17	04	K5+F8	95.2	49	6.3+6.7
Howe 94		13	48.9	- 35	42	F8+?	11.6	355	6.6+9.6
ι -Boo		14	16.2	+ 51	22	A5+?	38.5	33	4.9+7.5
$\alpha_{1,2}$ -Lib		14	50.9	- 16	03	A2+F5	231.0	314	2.8+5.2
ADS 10105/Her		16	31.8	+ 45	36	A0+F9	16.4	195	5.7+8.2
$\alpha_{1,2}$ -Her var.	*	17	14.6	+ 14	23	M5+G5	4.7	105	3.1-3.9 + 5.4
95-Her		18	01.5	+ 21	36	A3+G5	6.3	258	5.0+5.1
β -Cyg		19	30.7	+ 27	58	K3+B8	34.4	54	3.1+5.1
ADS 15764/Cep		22	12.9	+ 73	18	G5+A3	28.9	348	6.2+8.3
ADS 15881/Cep	*	22	21.8	+ 66	42	F5+A2	4.3	96	6.7+6.7
δ -Cep var.		22	29.2	+ 58	25	G0+A0	41.0	191	3.5-4.4 + 7.5

Furthermore, to be complete, these lists should include:

δ Cepheids (spectral variations with phase), Mira and U Gem stars (as above; attainable mostly in maximum only),

symbiotic stars (e.g. AG Peg), Be and P Cyg stars (variable emission lines or absorption borders), semiregular variables and novae (not foreseeable), some eclipsing variables (spectral changes during eclipse; e.g. VV Cep / ξ Aur / 31 + 32 Cyg). The curious owner of a large aperture telescope may be interested to look at Seyfert galaxies or related objects (e.g. NGC 4151 / BW Tau / W Com / OJ 287 / 3C371 / BL Lac) /22/.

For observing double stars the grating should be turned until the spectrum is perpendicular to a line connecting the two stars. The spectra can be distinguished at once by their different maxima in intensity of colors, coincidental with different surface temperatures. With close double stars it is better not to use the cylindrical lens.

Photography of Spectra

Comparable to "deep sky" photography, faint objects are detectable photographically which are not observable visually. Moreover, the photographic emulsion is much more sensitive to blue and red light than the human eye, especially under low light level conditions. Both B&W and color films are suitable. The structure of the latter are three layers of different color sensitivity, fixed to the emulsion support /14/. This results, except for very bright objects (where all colors of a continuous spectrum are reproduced without a gap), in a spectrum composed of three distinct color sections; sometimes only a red segment is seen on the film. B&W emulsions don't have uniform sensitivity for all colors either. In addition to a more or less pronounced "green-gap" the red may exceed the $H\alpha$ -line. This is similar to the short-wave blue limit. When comparing and evaluating photographic spectra, one has to consider the spectral sensitivity of the emulsion. Further data concerning this is available from the manufacturer. Using color emulsions frequently, it is not possible to adjust the exposure time for all spectral regions to be reproduced correctly. To compensate for this "bracketing" the exposure by exposing for various amounts of time is a good remedy. Otherwise the overexposed part of the spectrum has to be darkened by filtration unfortunately necessitating a much longer exposure time. Analysis of a spectrum is described in /9f,21/.

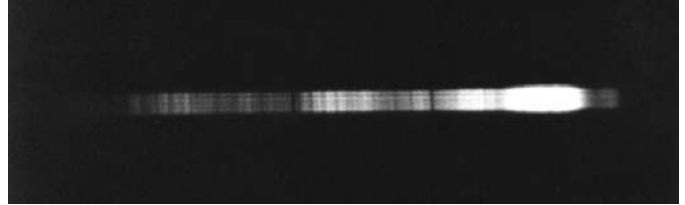

Aldebaran / Photo: Peter Stättmayer

Film: TP 2415, ~3 Minutes exposure time.

Optics: 5" NSC 12b Schmidt-Cassegrain / Baader Blaze-Grating-Spektrograph

Just as in Visual observation when using the cylindrical lens, absorption lines are only recorded photographically within slightly widened spectra. The most effective way to do this is by allowing the guide star to oscillate slowly in right ascension. You have the choice of three methods. Alternatively pressing the slow- and fast-buttons of the right ascension drive control for calculated periods of time allowing the guide star to drift an equivalent angle υ or by shifting the telescope by υ to the west, stopping the motor will bring the star back to the starting point. Thirdly the driving rate of the telescope can be changed slightly by a tested amount. Common to all methods, effective exposure depends on declination δ , increasing inversely to the latter's cosine. In basic terms, if $\delta = 60^\circ$ then $\cos 60^\circ = 0.5$, so solely by earth rotation the star's drift on the film plane is half the rate of a star on the equator ($\delta = 0^\circ$). The amount of starlight exposing an area of the emulsion is doubled. Sky background intensity remains unchanged so within same exposure time limiting magnitude for usable spectra is increased by 0.7m (for $\delta = 60^\circ$). Obviously this is valid as long as sky background isn't the limiting factor for exposure time.

Special attention is needed:

- for the exact guiding in declination, which is quite simple if the polar alignment is accurate, and
- for the lining up of the spectrum in a north-south direction done by turning the grating. Otherwise the definition of the spectrum will suffer. The right ascension widening suggested here requires less gauging than when done in declination because guiding adjustments within this coordinate will seldom be necessary compared with those needed for right ascension. This last would lead to an otherwise unnecessary, but not really unfavorable additional broadening of the spectrum.

The degree of the widening a can be adjusted to one's needs. It is determined by how fine the grain of the emulsion is which is to be used. It lies between $a = 0.2$ mm (e.g. for KODAK TP2415) and 0.5 mm (for films at ISO400/21°), and is equivalent to the angle υ , defined as:

$$\upsilon = 60 \times \arctan(a/f)$$

f being the focal length of the telescope, determined together with a in millimeters, whereas υ is put in arc minutes. From binary stars and planetary diameters, υ can be estimated by using the markings in the guiding eyepiece. Exposure time depends on a number of factors. It has to be estimated from the combination of star/telescope/spectrograph/and film used respectively. To keep this value as short as possible, the widening of the spectrum should be kept at a minimum. Referential values for exposure times can be calculated according to /8/.

Since collimators and image forming objectives are not used i.e. the grating is positioned within the convergent beam of light in front of the focal point of the telescope, fast systems such as Newtons should, for photography, best be used with a barlow lens or a teleconverter placed between the optical system and the grating to best minimize the effect of coma, astigmatism and curvature of field.

Area covering objects, especially those with a continuous spectrum such as Jupiter, Saturn, nebulae or galaxies, can only be spectrophotographed reasonably when using a slit. It has to be positioned exactly in the focal plane of the telescope. Behind it, as seen from the focal plane, a so-called collimator, i.e. a positiv lens or system of lenses, directs a

parallel beam. The collimator must have at least the same focal ratio as the telescope (or even be faster) and can consist of an achromat or binocular objective, or a 1¼" ocular with a long focal length. The slit is placed at its focal plane or, as in the case of the ocular, on the level of its focal stop. The slit can be made from two parallel aligned razor blades. Keeping the gap between them as small as possible is decisive for the spectral definition. The grating is placed in the parallel beam, emerging from the collimator. The resulting spectrum is projected on the film with the help of a further lens or lens system, usually a normal camera lens focused for infinity. Building such an Instrument on one's own is certainly not easy, considering that the length of the overall construction is increased due to the additional optical apparatus; furthermore considering that the extension must not bend or sag the least bit, and thirdly taking into account the additional weight which needs to be counterbalanced. To add on, one must pay attention to the need of the exact positioning of the object at the opening of the slit that demands a device similar to an "On-Axis-System" or a guiding scope. The advantage of such a "slit-spectrograph" is the total independence from seeing conditions and the minute influence of sky illumination, thus resulting in a definitively "deeper" range.

Further use of your Spectroscope:

Using the grating only (or grating and grating holder for safer handling) various sources of light can be studied. Select point or line sources or make a cardboard tube to mount the grating in one end and a pair of razor blades edge to edge but not touching in the other end. Flames will have continuous spectra with emission lines, when table salt is dropped in the flame. Continuous spectra of tungsten lights will be reddened when dimmed. Street lights are usually either tungsten or

- mercury vapor, looking bluish overall and yielding an emission spectrum
- high pressure sodium, looking pinkish overall and yielding a combination of continuous, absorption, and emission spectra
- low pressure sodium, looking golden overall and yielding an emission spectrum similar to table salt in a flame.

Especially advertising lights and lightnings are very interesting and may have strange spectra.

With a slit the spectroscope / spectrograph may be used to test colored filters or the spectral sensitivity of films. The light of the night sky, the best filtering against light pollution, and the changing of the light at dawn can be studied, as well as the screen of your color television, the welding arc or the different parts of a flame of gas.

Placing the grating in front of a photographic lens, the spectrum of the solar chromosphere (flash-spectrum) as well as bright comets, planets, nebulae, and meteors will be recorded. Please refer to /15,16,17,18,19,20,23,24/ for further reading.

Technical Data:

Typical grating for astronomical spectrographs have 100 to 1000 lines (grooves) per millimeter (L^*mm^{-1} / 2500 to 25.000 L^*inch^{-1}), Echelle gratings have 10 to 50 L^*mm^{-1} (25 to 1300 L^*inch^{-1}). The total number of grooves is between 1000 and 50.000 altogether. The chosen number of grooves always forms a compromise between the intended spectral definition and the speed of the spectrograph. Gratings are used for a range covering the first to the 200th order, so that their resolving power can be estimated at between 10^3 and 10^5 /11/. Then grating used for this spectrograph has been copied from the original using holographic technics in order to avoid faults in its optical Performance. It has 207 L^*mm (5318 L^*inch^{-1}) and at a diameter of 26mm totals to 5400 grooves. Since it has been blazed for the first order, its resolving power is 5400 so that theoretically $<0.1nm$ can be resolved. This is a value not normally achieved under normal viewing conditions with normal films without using a slit. In its regular form i.e. without additional extension pieces between the grating and the ocular and camera respectively, the spectrum of the first order is about 12 arc minutes long and has about 14 - 26 arc minutes spacing to that of the zero order. On film, the length of the spectrum is about 6mm, the resolution is about $48nm^*mm^{-1}$.

The Blaze-Grating Spectroscope consists of the following parts:

1. Blaze-Grating, mounted in eyepiece filter cell.
2. Sliding T-2 focuser / Blaze-Grating Holder
3. Eyepiece Adapter for Cylindric Lens
4. Cylindric Lens
5. Rubber Eyeguard

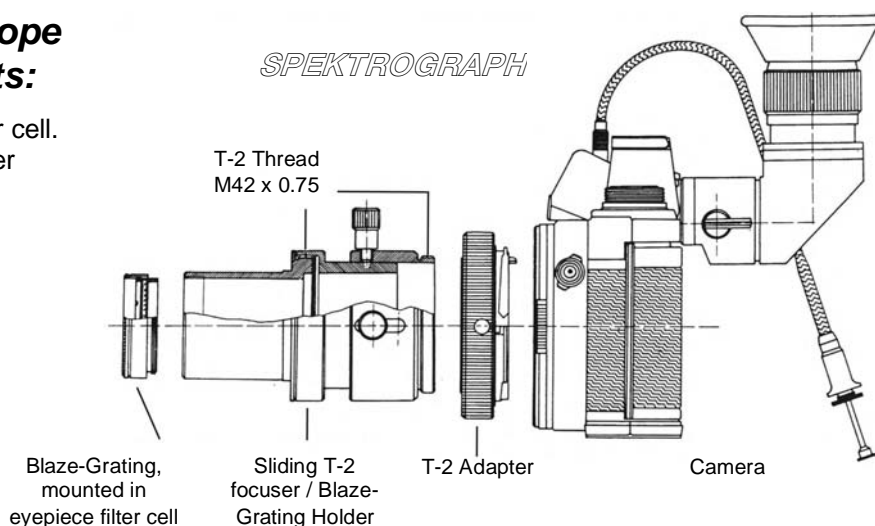

Literature:

- /1/ F.Giesecking: Planetarische Nebel Teil 1-6.
Sterne und Weltraum 22, 74, 224, 336, 524 (1983); 23, 15, 178 (1984)
- /2/ K.G.Jones: Webb Society Deep-Sky Observer's Handbook, Vol. 2, Planetary and Gaseous Nebulae.
Enslow Publishers, Inc., Hillside, N.J. 1979
- /3/ A.Hirshfeld, R.W.Sinnot: Sky Catalogue 2000.0, Vol. 1+2, Cambridge University Press, New York;
Sky Publishing Corp., Cambridge, Mass. 1985
- /4/ H.H.Voigt: Abriss der Astronomie. Bibliographisches Institut Mannheim / Wien / Zürich 1980,S.136.
- /5/ K.G.Jones: Webb Society Deep-Sky Observer's Handbook, Vol. 1,
Double Stars. Enslow Publishers, Inc., Hillside, N.J. 1986
- /6/ E.J.Hartung: Astronomical objects for southern telescopes. Cambridge University Press, Cambridge 1968
- /7/ J.B.Kaler: Extraordinary Spectral Types. Sky & Telescope 75, 149 (1988)
- /8/ W.Knapp, H.M.Hahn: Astrofotografie als Hobby. vwi-Verlag, Herrsching 1980
- /9/ P.Martinez: Astronomie le guide de l'observateur.Tome 2. Edition Societe d'Astronomie Populaire, 1987
- /10/ J.B.Sidgwick: Amateur Astronomer's Handbook. Enslow Publishers, Inc., Hillside, N.J. 1986
- /11/ C.R.Kitchin: Astrophysical Techniques. Adam Hilger Ltd., Bristol 1984
- /12/ K.Schaifers, G.Traving: Meyers Handbuch Weltall. Bibliographisches Institut, Mannheim / Wien / Zürich 1984
- /13/ G.Walker: Astronomical Observations, An Optical Perspective. Cambridge University Press, Cambridge 1987
- /14/ B.D.Wallis, R.W.Provin: A manual of advanced celestial photography. Cambridge University Press,
Cambridge 1988
- /15/ S.J.Edberg: Exploring the stars with a spectrograph. Sky & Telescope 64,311 (1982)
- /16/ F.Dossin: Spectra of comet Tago-Sato-Kosaka. Sky & Telescope 39,152 (1970)
- /17/ Sky & Telescope 65, 332 (1983)
- /18/ Sky & Telescope 50, 284 (1975)
- /19/ J.Cuffey: The Spectrum of a City. Sky & Telescope 50, 155 (1975)
- /20/ DeVorkin: The Dawn of Balloon Astronomy. Sky & Telescope 72, 579 (1986)
- /21/ H.A.Abt, A.B.Meinel, W.W.Morgan, J.W.Tapscott: An Atlas of Low-Dispersion grating Stellar Spectra
- /22/ K.G.Jones: Webb Society Deep-Sky Observer's Handbook, Vol. 4, Galaxies.
Enslow Publishers, Inc., Hillside, N.J. 1986
- /23/ A.W.Peterson, L.M.Kieffaber: The Twilight Flash of Sodium. Sky & Telescope 41,344 (1971)
- /24/ A.M.MacRobert: Celestial Calendar; A Bright Galactic "Monster" Sky & Telescope 75, 292 (1988)



BAADER PLANETARIUM G
M
B
H

Zur Sternwarte • 82291 Mammendorf • Tel.08145/8802 • Fax 08145/8805
www.baader-planetarium.de • service@baader-planetarium.de • www.celestron.de